

OAKLAND CUSD #5

3RD GRADE
MAY 1 1-15, 2020

DEDE CHILDRESS

Week of May 11-15

Mrs. Childress's 3rd Grade

Mrs. Childress's office hours:

Monday 8-10am

Tuesday 10-12

Wednesday 12-2pm

Thursday 2-4pm

You may email completed work to dede.childress@oakland5.org (or drop off at school) every Monday.

Subject	Choice 1	Choice 2	Choice 3
Math (Choose 1 to turn in)	Do 2 rounds of Xtra Math. See instructions below.	Complete a Drops in the Bucket. (attached #33)	Complete the word problems that are attached.
Reading (Choose 1 to turn in)	Read a story of your choice and answer the 10 questions.	Read a story of your choice and write a 5 sentence summary.	Read a story of your choice and complete a book report. (2 pages)
Writing (Choose 1 to turn in)	Write a letter to a future 3rd grader. I will put in their desks for them to read next year.	Write a paragraph (5 complete sentences)telling me your best memory from 3rd grade.	Make up your own story. Must be one page long.
Free Choice Option #1 (Choose 1 to turn in)	Read the latest Scholastic News and answer the questions on the back page. To read the digital copy: go to http://sn3.scholastic.com/ click Login (top right), Choose- "I am a student" and use the password: childress2020	Use your Social Studies textbook to write the definitions listed on the attached worksheet. (2 pages)	Use your Social Studies textbook to answer the attached review questions.
Free Choice Option #2 (Choose 1 to turn in)	Use your Science textbook to write the definitions listed on the attached worksheet. (3 pages)	Use your Science textbook to answer the attached review questions.	Use your Science textbook to answer the following critical thinking questions.

*Xtra Math: go to xtramath.org - click "sign in" (top right)- for the email use:

kelly.mcconaha@oakland5.org- type in your child's name and their Pin # (Mrs. McConaha will send me the report that shows who has completed for your grade)

Mrs. Childers 3rd Grade
May 11-15
Choice # 2

Name _____

Score _____

1

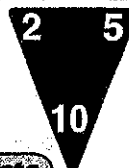

2 x 5 = _____
5 x 2 = _____
10 ÷ 2 = _____
10 ÷ 5 = _____

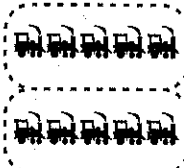



2 x 8 = _____
8 x 2 = _____
16 ÷ 8 = _____
16 ÷ 2 = _____

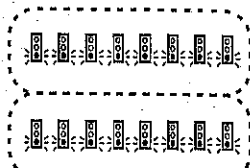

Basic Facts

2

Write the numbers that come before and after.

_____ 391 381 371 _____

Patterns and Progressions

3



AI

AI ate 2/3 of a small pizza.
John ate 2/3 of a large pizza.
Who had more to eat? _____



Johnny

Fractions

4

Put numbers on the clock to show the time at one minute after five o'clock.



Time

5

477 + 63 = _____ 355 - 18 = _____

Algorithms

6

seventy thousand five hundred four



Number Words

7

I had a bag of 15 peanuts. I ate three of them and fed nine to the squirrels. How many peanuts were left?



Story Problems

8

If a number ends in one, three, five, seven, or nine, you know it is _____.

(even, odd)

Words and Symbols

9

Draw bars on the graph to show that 7 walk, 13 ride the bus, 9 come by car, 1 skates, and 3 bike to school.

How We Come to School

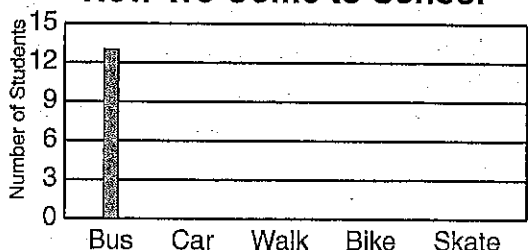

Place Value, Graphs, and Geometry

10



Write the amount in words and numbers.

Money

Name : _____

Score :

Mrs. Childress 3rd Grade

Teacher : _____

Date :

May 11-15

Choice # 3

Word Problems

2 of 17

1) Keith has thirty blue balloons. He wants to give his six friends the same number of blue balloons, how many will each friend get ?

2) Melanie was at the beach for five days and found 20 seashells. She plans to give all of her seashells equally to her four friends. How many seashells will each friend get ?

3) Benny has 50 cents in his bank. How many dimes does Benny have ?

4) There were a total of 15 football games during the three month season. If the games are equally divided, how many football games are played a month ?

5) Fred worked twenty-five hours in the last five days. Assuming that he worked the same amount of hours each day, how long did he work each day ?

6) Mary goes out to lunch with Jason and Melanie. The total bill came to eighteen dollars. They decided to equally split up the bill, how much will each person have to pay ?

7) Sally goes fishing with Mike. They catch ten trout. If they equally split up the trout, how may will each one get ?

8) A restaurant sold thirty-five cakes last week. How many cakes on average were sold each day ?

9) Alyssa has 25 dollars in five dollar bills. How many five dollars bills does she have ?

10) Dan, Nancy, and Sandy have 15 erasers all together. If the erasers are equally divided, how many will each person get ?



Mrs. Childress

3rd Grade

Week: 6 May 11-15

Reading Choice #1

Directions: Read a book of your choice and answer the following questions *in cursive*.

Name: _____

Title of Book: _____

Author: _____

If it is a chapter book, tell me the pages you read: _____

Please answer each question in complete sentences and in your best cursive handwriting.

1. Could this story be true? Why or why not?
2. Where is the setting of the story?
3. Who is this story about?
4. What 3 words would you use to describe the main character?
5. Do you like the main character? Why or why not?
6. Does the main character have a problem? Why or why not?
7. How is the problem solved?
8. What is the scariest, saddest, most interesting, or most funny part of the story?
9. Do you like the story? Why or why not?
10. Would you recommend this book to a friend? Why or why not?

Mrs. Childress

3rd Grade

Week: 6 May 11-15

Reading Choice #2

Directions: Read a book of your choice and answer the following questions *in cursive*.

Name: _____

Title of Book: _____

Author: _____

If it is a chapter book, tell me the pages you read: _____

Directions: Write a summary of the story. Must be at least 5 sentences. Tell what happened in the beginning, middle, and end of the story.

Mrs. Childress

3rd Grade

Week: 6 May 11-15

Reading Choice #3

Directions: Read a book of your choice and answer the following questions. Answers should be written in complete sentences and in your best cursive handwriting.

Name: _____

Title of the Book: _____

Main Characters: _____

Setting of the Book: _____

What genre was the book you read? (fiction, nonfiction, historical fiction, fantasy, realistic fiction, fable, science fiction, mystery, biography) Circle one.

What happened in the beginning of the book? _____

What happened in the middle of the book? _____

PAGE 2

Mrs. Childress

3rd Grade

Week: 6 May 11-15

Reading Choice #3

What happened at the end of the book? _____

What was your favorite part of the book and why? _____

Mrs. Childress
3rd Grade
Week: 6 May 11-15
Writing Choice #1

Name: _____

Directions: Write a letter to a future 3rd grader. I will put them on their desks for them to read on the first day of school.

Dear 3rd grade student,

Sincerely,

Mrs. Childress

3rd Grade

Week: 6 May 11-15

Writing Choice #2

Name: _____

Directions: Write a paragraph telling me about your favorite memory from 3rd grade. Must be at least 5 complete sentences.

Mrs. Childress
3rd Grade
Week: 6 May 11-15
Free Choice Option #1- Choice #2

Name: _____

Using your social studies book, find the vocabulary words listed below and write out (or type) the definition of each word. Vocabulary words will be in Chapter 5- Pages 114-131.

suburb: _____

commute: _____

Assembly line: _____

pollution: _____

Planned community: _____

PAGE 2

Mrs. Childress

3rd Grade

Week: 6 May 11-15

Free Choice Option #1- Choice #2

Name: _____

habitat: _____

ferry: _____

Mrs. Childress

3rd Grade

Week: 6 May 11-15

Free Choice Option #1- Choice #3

Name: _____

Directions: answer the following questions using your Social Studies textbook. Answers will be in chapter 5 pages 114-131.

1. Why do so many people live in suburbs today?
2. How did Henry Ford build cars quickly and cheaply?
3. Describe how Levittown, New York, was built.
4. How can building new suburbs cause problems for animals?
5. Where is the largest suburban area in the world?

Mrs. Childress
3rd Grade
Week: 6 May 11-15
Free Choice Option #2- Choice #1

Name: _____

Directions: Use your science textbook to write down the definition of each word. These will be found in Chapter 4 pages 97-127.

producer: _____

consumer: _____

herbivore: _____

carnivore: _____

omnivore: _____

PAGE 2

Mrs. Childress

3rd Grade

Week: 6 May 11-15

Free Choice Option #2- Choice #1

Name: _____

prey: _____

predator: _____

competition: _____

decomposer: _____

decay: _____

germs: _____

PAGE 3

Mrs. Childress

3rd Grade

Week: 6 May 11-15

Free Choice Option #2- Choice #1

Name: _____

disease: _____

Mrs. Childress

3rd Grade

Week: 6 May 11-15

Free Choice Option #2- Choice #2

Name: _____

Directions: Answer the following questions using your science textbook. Use chapter 4 pages 97-127.

1. A(n) _____ eats only animals while a(n) _____ eats only plants.
2. Bacteria and viruses are _____ which can cause _____.
3. A(n) _____ is a consumer that hunts another for food.
4. A(n) _____ is a living thing that must eat food to get energy.
5. A(n) _____ makes its own food.
6. _____ happens between living things that have a need for the same resources.
7. A(n) _____ eats both plants and animals.
8. _____ happens when a(n) _____ breaks down a living thing that has died.
9. _____ is an animal that is hunted by others.

Mrs. Childress

3rd Grade

Week: 6 May 11-15

Free Choice Option #2- Choice #3

Name: _____

Directions: Answer the following questions using your science textbook. Use chapter 4 pages 97-127.

1. Trace the flow of energy from beginning to end in the following food chain: a ferret eats prairie dogs which eat grasses and other plants. (draw the food chain)
2. Explain why some plants that are put into a new area can become dangerous weeds.
3. Explain the helpful and harmful effects ground fires have on plants in a forest community.
4. Describe ways to stay healthy.

Week of May 4-15, 2020
3rd Grade Art
Mrs. Sweeney

Please pick 1 out of the 3 activities to complete every other week. Please email me a picture of your child completing the activities or submit the activity to the homework box located in the Lake Crest foyer. Some of the art projects require supplies. Please feel free to improvise if you do not have the required supplies, or reach out to me or the office and we will work together to get you what we need. Some basic supplies will be available for pick-up in the Lake Crest foyer.

Please email me at jill.sweeney@oakland5.org or call the school and leave a message, and I will give you a call as soon as I can. My office hours are 8-10 am on Mondays and Wednesday and Tuesdays 10-12. I will be readily available at those times.
School office hours: Monday-Thursday 7:30-11:30 and the phone is 217-346-2166.

If email submission is not an option, contact Mrs. Sweeney for alternative ways to submit work. Sketchbooks and Still Life Drawings can be placed in the Homework Turn-in box in the Lake Crest Foyer.

Class	Choice 1	Choice 2	Choice 3 (Enrichment)
3rd Grade	Toucan	Jaguar	Petunia

Draw a Toucan

3rd grade / Christal / Sweeney
May 4-15

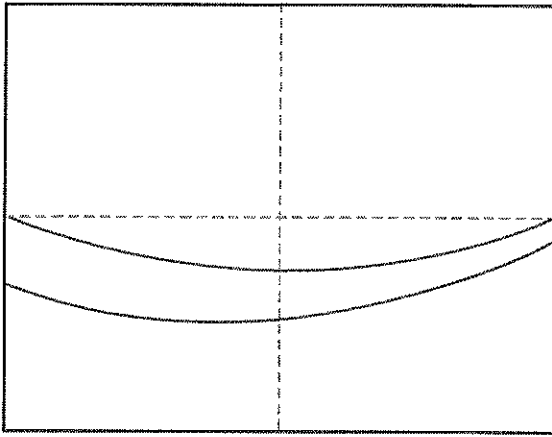

1. Draw a curvy branch.

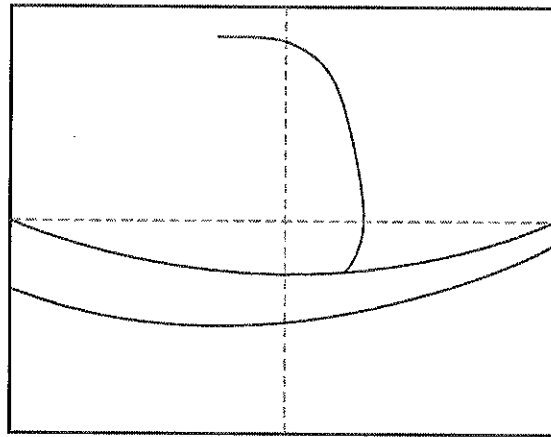

2. Draw one side of the body.

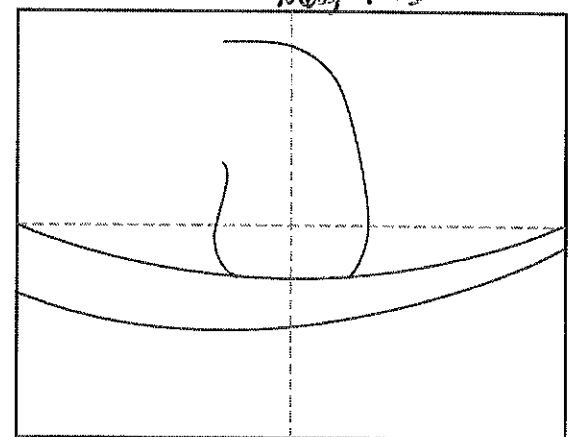

3. Draw the other side, with opening for beak.

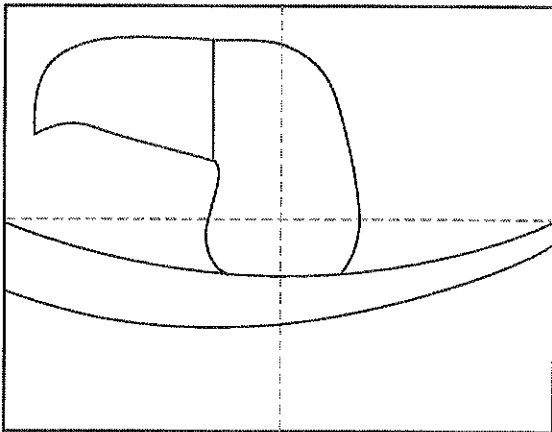

4. Attach a large beak.

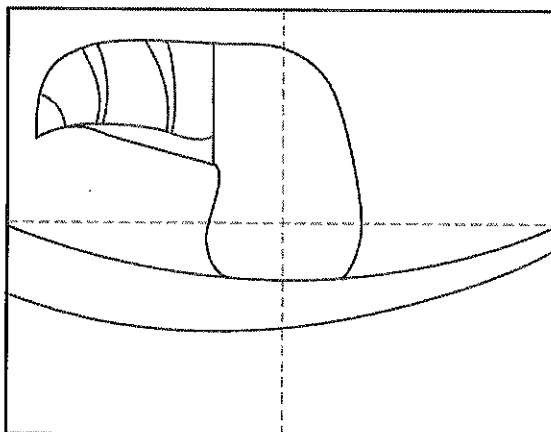

5. Add the beak details shown.

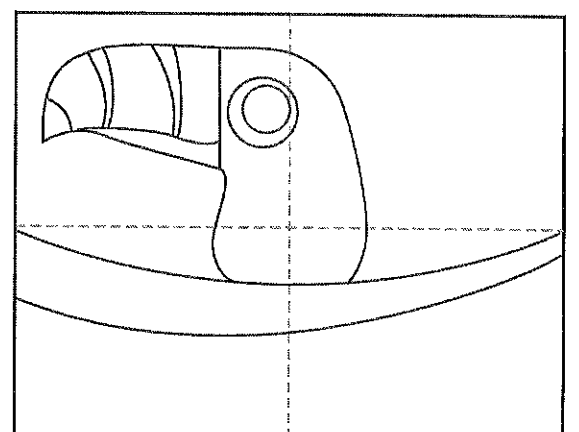

6. Draw two circles for the eye.

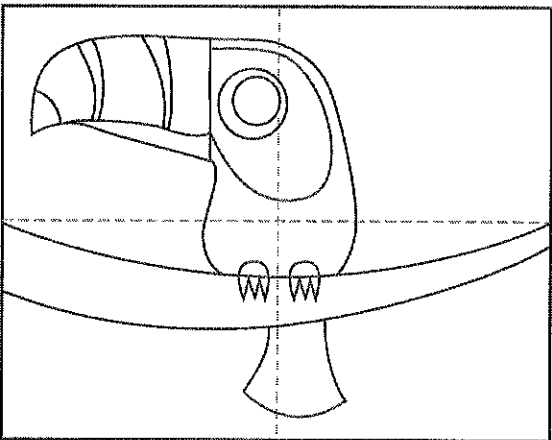

7. Add line around the eye, claws and tail.

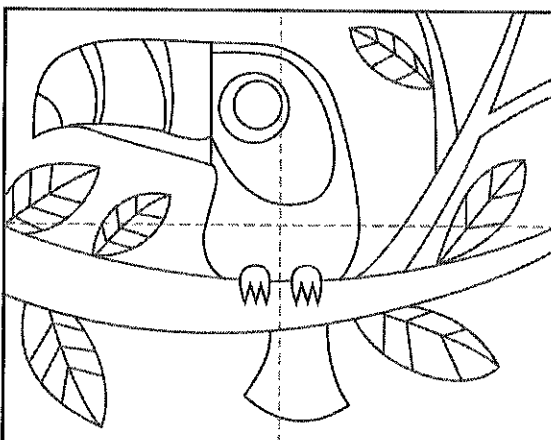

8. Fill the background with branches, leaves.



9. Trace with a marker and color.

Draw a Jaguar

3rd grade / choice 2 / Sweeney
May 4-15

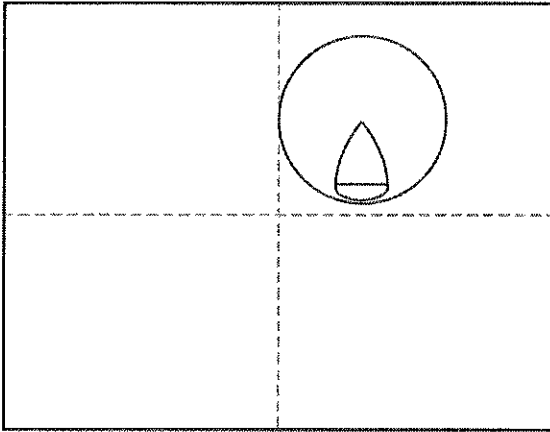

1. Draw a circle and nose.

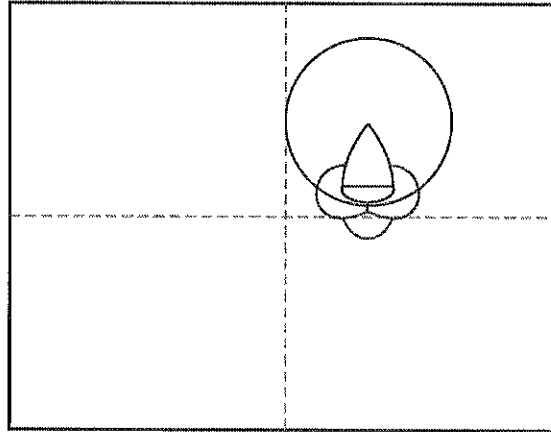

2. Add the cheeks and mouth below.

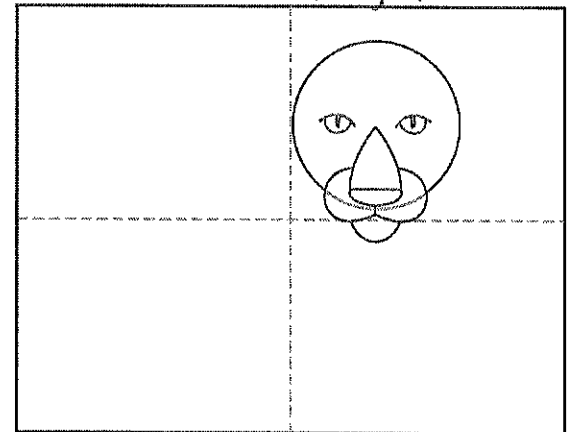

3. Draw two eyes. Erase the gray lines.

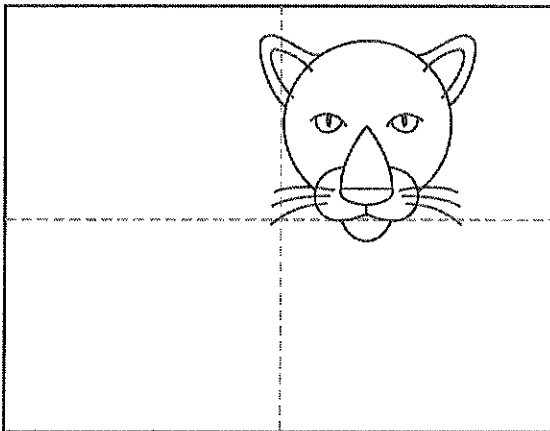

4. Add two ears and whiskers.

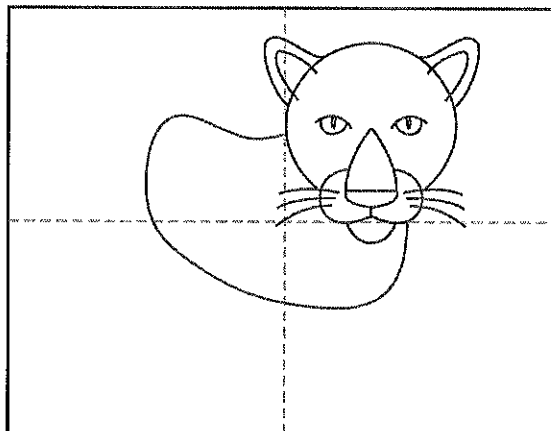

5. Start the body below. This is in perspective.

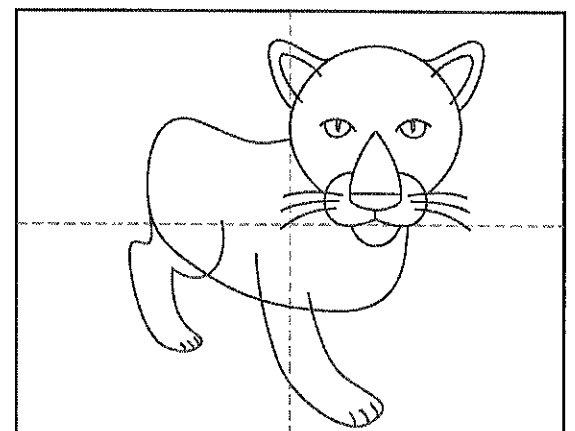

6. Draw the two legs on one side.

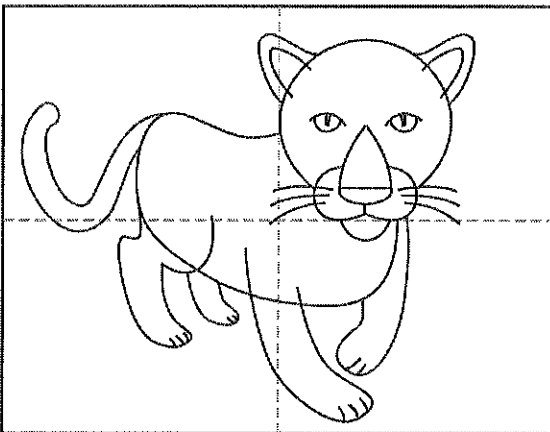

7. Add the legs on the other side, and tail.

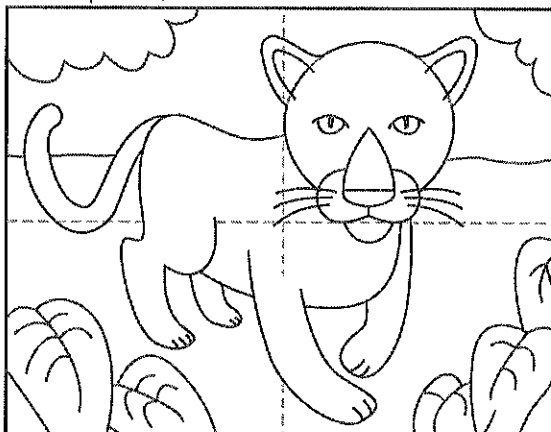

8. Draw horizon line, leaves. Erase gray lines.

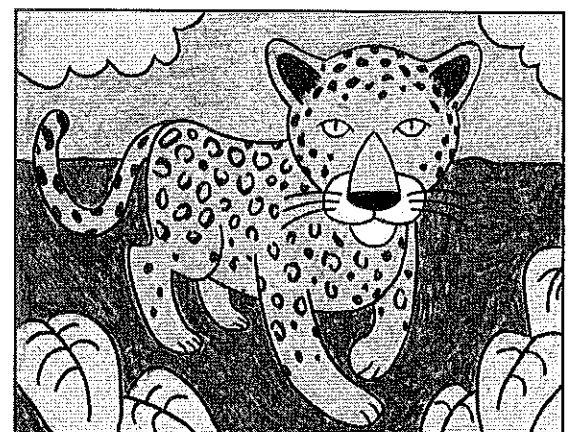

9. Trace with a marker and color.

Petunia

3rd grade/choice 3/Sweeney

Watch the book Petunia on youtube: <https://www.youtube.com/watch?v=krV2p6FJyYc>



Materials:

12" x 18" white paper or what you have available

Pencil and Eraser

Red, yellow, white, blue, green and black liquid tempera paint (or crayons)

Paint brush if painting

Black marker, black crayon or lack oil pastel as optional outing supplies.

Directions:

1. Draw Petunia

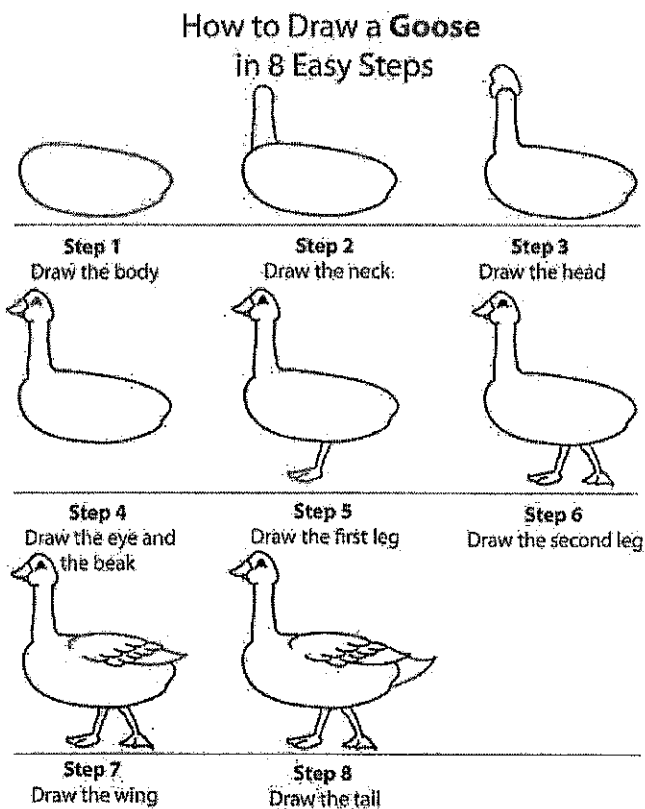

2. Draw flowers around Petunia.

3. Paint/color the background red.

4. Let dry and paint flowers.

5. Let dry and with a black crayon outline Petunia and flowers.

Weeks of *May 4-15,* 2020 April Lee

Hello! This will be our final packet for Music this school year. It is with mixed emotions that I send it out to you. I feel sad we didn't get to have our Spring Concert, but I feel glad that Spring is in the air and Summer is just around the corner. Here's wishing you and your families all the best this season and the next!!!

Please don't forget about the Facebook group called Lake Crest Music. I believe I have invited everyone K-5. Each day or so I try to find some activity we can do together. Send me an email or make a comment if you liked a particular activity.

To complete Options #1 & #2 students will need a pencil. For Option #3, crayones will be needed. This work is due May 15.

My "office hours" are from 10:00 a.m. to noon on Mondays, Wednesdays, & Thursdays, but you can email me anytime with questions or concerns at april.lee@oakland5.org.

Class	Choice 1	Choice 2	Choice 3 (Enrichment)
3rd Grade Music	Play a Tune word search	John Philip Sousa	Color by Note

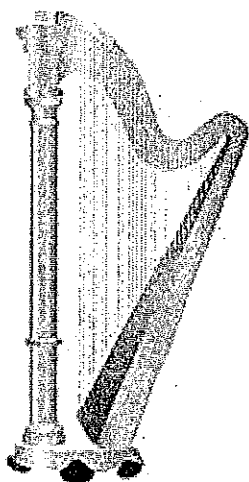

Play a Tune



ACCORDION
 BANJO
 CELLO
 CLARINET
 DRUM
 FLUTE
 GUITAR

HARMONICA
 HARP
 MARIMBA
 ORGAN
 PIANO
 RECORDER
 SAXOPHONE

TRIANGLE
 TRUMPET
 TUBA
 XYLOPHONE

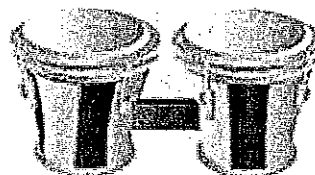

Mrs. Lee

Music

3rd grade

John Phillip Sousa

Option #2 p.1

May 4-15



1854-1932

Romantic-Modern Period

"The March King," John Phillip Sousa, was born in Washington D.C. His father played trombone in the United States Marine Band. Sousa always loved bands and when he was 13, he almost ran off to join a circus band. His father found out about his plan and enlisted him in the Marine Corps instead.

Sousa studied and played many instruments including the flute, cornet, baritone, trombone, French horn, and violin. He met his wife playing the violin for a theater production.

Eventually, Sousa returned to the band world. He spent 12 years conducting the Marine Band and then started his own band that toured the world. Sousa also directed the President's Own Band under 5 presidents and served in World War I. He received the World War I Victory Medal.

Sousa died suddenly after conducting a band rehearsal where they had just played "The Stars and Striped Forever"

Famous Works

Stars and Stripes Forever

*National March of the United States

Semper Fidelis

*Official March of the Marine Corps

Washington Post March

May 4-15

Option #2 p.1

3rd grade

Music

Mrs. Lee

Mrs. Lee

Music

3rd grade

Option #2 p.2

May 4-15

Name: _____

Class: _____

John Phillip Sousa

(Dates)

(Period of Music)

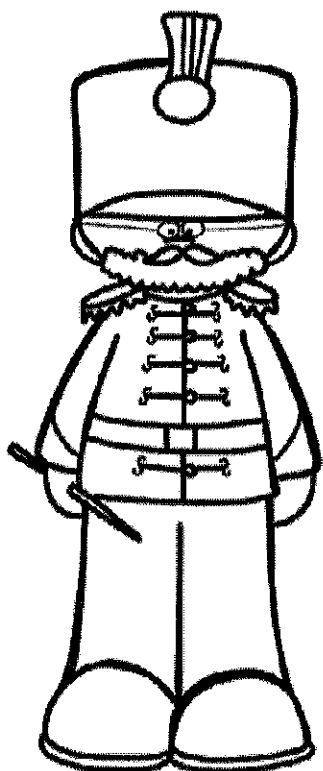

1. Famous _____ composer

2. Sousa was known as the _____ King.

3. He played many instruments including the _____, cornet, baritone, French horn, and _____.

4. Sousa conducted the _____ Band for 12 years before starting his own band that toured the world.

5. Sousa also conducted the _____ Own Band under 5 Presidents.

6. Sousa served in _____ and received the Victory Medal for his service.

Famous Works



Option #2 p.2

3rd grade

Music

Mrs. Lee

Color By Note

Quarter Notes = Light Blue
Quarter Rests = Brown
Eighth Notes = Red

Half Notes = Yellow
Half Rests = Dark Blue

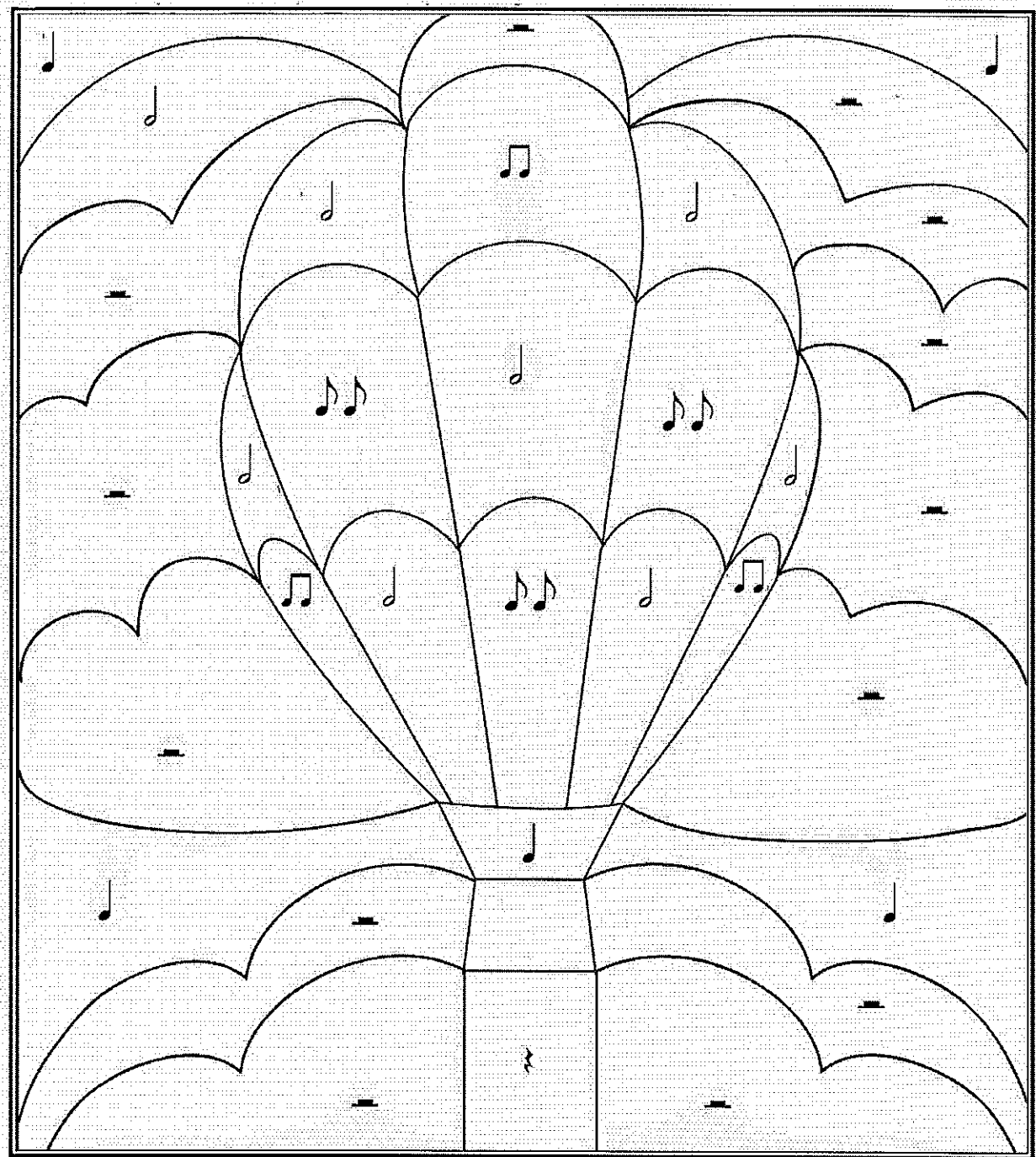

Week of May 11 - May 15 2020
2nd/3rd PE
Coach Kappy

Please pick 3 out of the 5 activities to do for the week. Please email me a picture of your child completing the activities and the dates or email me a description of the activities. You or your child may also write a few sentences about the activity and submit to the homework box located in the Lake Crest foyer.

Please email me at jenny.kapraun-veach@oakland5.org or call the school and leave a message, and I will give you a call as soon as I can.

Class	Choice 1	Choice 2	Choice 3	Choice 4	Choice 5
2nd/ 3rd Grade	Ride your bike for 15-20 minutes	Do an exercise Video/have a Dance Marathon	Go on a walk with your family or with a parent for 15-20 minutes	Play Basketball for 15-20 minutes.	Another physical activity that you do for 15 minutes or more (yard work, etc.)